

**Physikalisch  
Technische  
Bundesanstalt**

**PTB-Bericht**

**Jürgen Helmcke and Siegfried Penselin (Eds.)**

Proceedings of the Workshop

**Frequency Standards Based on Laser-Manipulated Atoms and Ions**

February 12-14, 1996, in Schierke, Germany

PTB-Opt-51  
Braunschweig, April 1996

ISSN 0341-6712  
ISBN 3-89429-719-0

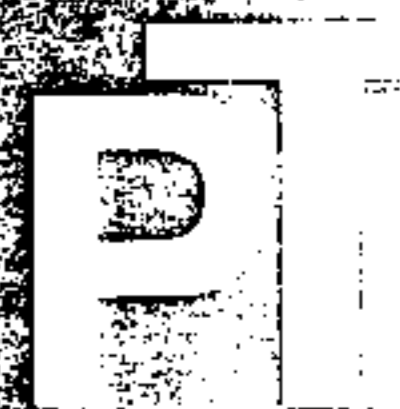

# A PHASE-COHERENT FREQUENCY CHAIN CONNECTING A METHANE STABILIZED HE-NE LASER TO THE HYDROGEN $L_{\alpha}$ -TRANSITION FREQUENCY

Th. Udem, A. Huber, M. Weitz, D. Leibfried\*, W. König, M. Prevedelli<sup>†</sup>, A. Dmitriev<sup>‡</sup>  
and T. W. Hänsch

Max-Planck Institut für Quantenoptik, Hans Kopfermann-Str.1, 85748 Garching, Germany

**Abstract**– We have constructed and tested a phase-coherent frequency chain leading from the  $3.39\ \mu\text{m}$  radiation of a methane stabilized HeNe Laser to the  $243\ \text{nm}$   $1s$ – $2s$  two-photon transition in atomic hydrogen. In our setup we take advantage of the close coincidence of the  $28^{\text{th}}$  harmonic of the methane transition with the  $L_{\alpha}$   $1s$ – $2s$  frequency. However, as the coincidence does not hold exactly there is a frequency gap in our chain of about  $1\ \text{THz}$  that is bridged with the help of cascaded optical frequency interval dividers [1].

For many years high resolution spectroscopy on atomic hydrogen has been essential for the development and testing of fundamental theories. Today the precise determination of relations of transition frequencies in atomic hydrogen provides one of the most rigorous verification of QED [2, 3, 4]. According to the Schrödinger theory 2 times the  $2s$ – $4s$  transition frequency should be half of the  $1s$ – $2s$  transition frequency. By longitudinal Doppler-free two-photon excitation of a cold hydrogen beam we have observed the beat frequency between the frequency doubled IR radiation, used to drive the  $2s$ – $4s$  transition, and the blue light used to drive the  $1s$ – $2s$  transition after being frequency doubled. If the well-known fine and hyperfine structure and the first order correction of the Dirac energies due to the finite nuclear mass is subtracted, this beat contains a combination of Lamb shifts of the involved levels. On the other hand, if one believes in QED, a more accurate value of the proton charge radius can be extracted from those frequencies. Optical frequency measurements in atomic hydrogen provide the most precise values of the Rydberg constant to date [5, 2, 6]. From the comparison of the transition frequencies in hydrogen and deuterium the deuteron structure radius can be extracted. A survey of recent developments in high resolution hydrogen spectroscopy and its theoretical treatment is presented in [7].

The sharp  $1s$ – $2s$  transition with its natural linewidth of only  $1.3\ \text{Hz}$  at  $2466\ \text{THz}$  may also eventually provide a new time standard, if convenient ways for the down conversion to radio frequencies are developed. One of the techniques currently under discussion is the use of cascaded optical frequency interval dividers [1]. In this work we are employing this technique for a phase-coherent measurement of the hydrogen  $1s$ – $2s$  transition frequency.

In an optical divider stage there are two lasers oscillating at frequencies  $f_1$  and  $f_2$ . The second harmonic of a third laser,  $2f_3$ , is phase-locked to the sum frequency of  $f_1$  and  $f_2$  making  $f_3$  equal to  $(f_1 + f_2)/2$ . Thus the frequency gap between  $f_1$  and  $f_2$  is divided by two. Phase locking of two optical frequencies is achieved by electronic means if the phase of the beat signal is locked to zero or, to reduce  $1/f$  noise, to a given offset radio frequency [8]. Techniques of conventional radio frequency phase-lock loops can be applied. In the coherent phase-locked condition we do not only divide the frequency gap but also the accumulated optical phase. This enables us to improve the accuracy by waiting an appropriate number of optical cycles. For example if the rms phase fluctuation

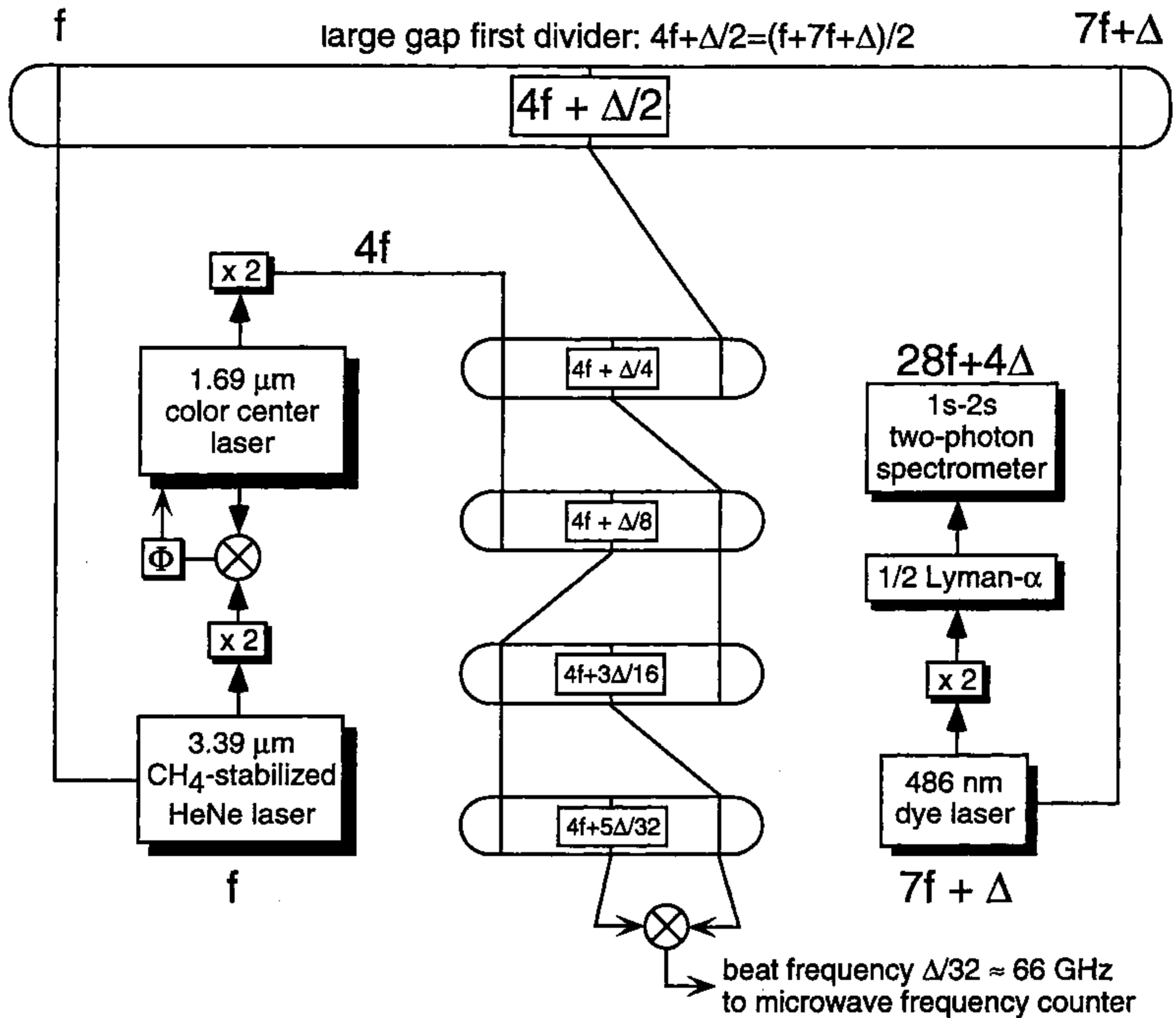

Figure 1: Scheme of the harmonic laser frequency chain and cascaded frequency interval dividers to measure the 1s–2s transition frequency in hydrogen. All lasers used in the divider stages, except the two starting frequencies  $f$  and  $7f + \Delta$ , are diode lasers.

stays below 1 cycle it is usually sufficient to wait 1 sec in order to transport an accuracy of more than  $10^{-14}$  depending on the absolute number of optical cycles in one second. This is an important point if one wants to use relatively broadband grating stabilized laser diodes. If  $n$  such divider stages are used the initial frequency gap is divided by  $2^n$ .

In Fig. 1 our current experimental setup is shown. The optical reference frequency is provided by a transportable methane stabilized HeNe laser that has been build by the group of Prof. Bagayev at the Institute of Laser physics in Novosibirsk, Russia [10]. The frequency of this laser is close to the 28<sup>th</sup> subharmonic of the 1s–2s transition frequency. It has been proven to be reproducible to 3 parts in  $10^{-13}$  by calibrating it with the German atomic cesium time standard at the PTB in Braunschweig using their harmonic frequency chain [12]. After generating the second harmonic of this laser, a NaCl:OH<sup>-</sup> color center laser is used as a transfer oscillator to provide enough power for the next nonlinear process. The fourth harmonic of the HeNe standard is created through frequency doubling of the output of the color center laser. This takes us to 848 nm where we employ grating tuned diode lasers [11]

In a first divider stage we create the frequency  $4f + \Delta/2$  that is near the fourth harmonic of our HeNe standard. This is done by dividing the large gap between the frequency  $f$  of the HeNe standard and the frequency  $7f + \Delta$  of the dye laser at 486 nm, whose second harmonic is used to excite the two-photon 1s-2s transition. Since the dye laser is oscillating at a quarter of the Lyman alpha frequency, it is also close to the 7<sup>th</sup> harmonic of the HeNe standard. The following cascaded divider stages reduce the remaining frequency gap of  $\Delta/2 \approx 1$  THz to about 66 GHz which can be counted after mixing it on a Schottky diode with a precisely known radio frequency. As it is possible to insert the divider stages anywhere in the harmonic frequency chain we choose to work at the 4<sup>th</sup> harmonic of the standard, around 850 nm, where diode lasers are readily available. The entire system now works reliably and can remain locked without cycle slips for periods of hours. We hope to get reproducible and improved values for the hydrogen 1s-2s frequency soon.

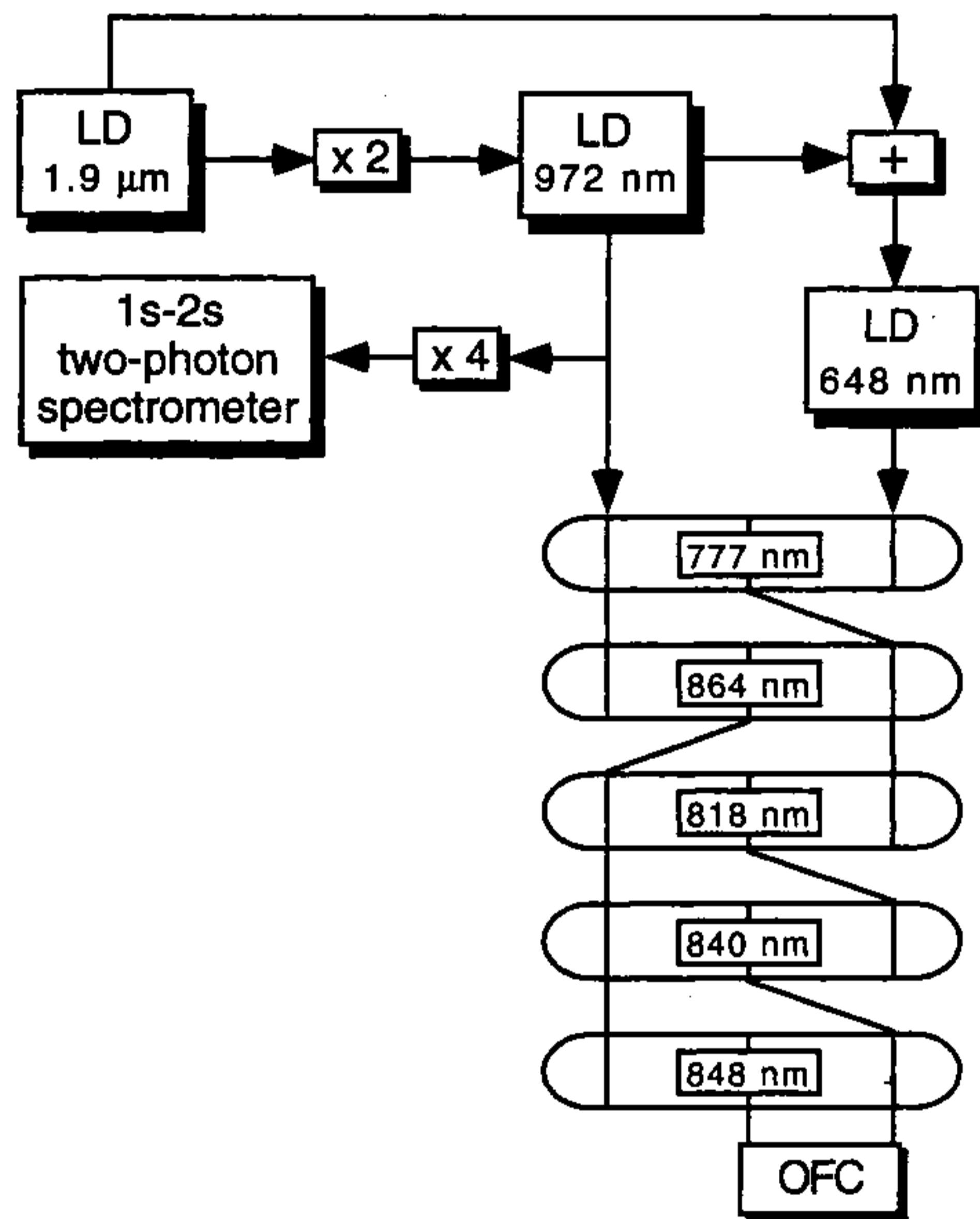

Figure 2: Proposed scheme for the application of cascaded frequency interval dividers to measure the 1s-2s transition frequency in hydrogen with laser diodes (LD) only. The remaining gap of  $\Delta\lambda = 8$  nm can be bridged with an optical frequency comb generator (OFC).

In a future application a cascade of optical frequency interval dividers may be used for the measurement of an absolute optical frequency by first doubling that frequency followed by a successive division of the gap between the fundamental and the second harmonic. The second harmonic generation can be thought of as a divider stage with  $f_1 = 0$ . In a

conventional harmonic frequency chain we have  $f_1 = 0$  in every step fixing the path down to the radio frequency domain. If optical divider stage with  $f_1 \neq 0$  are used, it is possible to choose the most convenient way where diode lasers and highly efficient nonlinear crystals are available. It is exactly this freedom of choice that makes the concept of divider stages more flexible. If this technique is used in connection with compact nonlinear frequency comb generators [9], that are now able to bridge frequency gaps of several THz, the number of divider stages can be reduced significantly. An example of a similar scheme for measuring the absolute-frequency of the 1s–2s two-photon resonance in atomic hydrogen is shown in Fig.2. The direct creation of the fourth harmonic of a laser diode at 972 nm with two successive frequency doubling stages has already been demonstrated [13].

In conclusion we have set up for the first time a phase-coherent multistage optical frequency interval divider chain. Even though optical frequency comb generators are now available to bridge gaps of several THz we would like to demonstrate the performance of our divider chain in an improved measurement of the 1s–2s two-photon resonance in atomic hydrogen. Unlike comb generators the size of the frequency gap that can be bridged with optical dividers is not limited. In addition it is possible to use this scheme in the measurement of absolute optical frequencies and for the down conversion of a future optical primary time standard.

We are indebted to G. Kramer and B. Lipphardt, PTB Braunschweig and to D. Tyurikov, P.N. Lebedev Institute, Moscow for their essential support in the calibration of the infrared reference laser. This work has been supported in part by the Deutsche Forschungsgemeinschaft.

\* new address: NIST, 325 Broadway, Boulder CO 80303, USA

† permanent address: LENS, Largo E. Fermi2, Florence, Italy

‡ permanent address: Institut of Laser Physics, Novosibirsk 630090, Prospekt Laventyev, Russia

## References

- [1] H. R. Telle, D. Meschede, and T. W. Hänsch: *Opt. Lett.* **15**, (1990)532.
- [2] S. Bourzeix, B. de Beauvoir, F. Nez, M.D. Plimmer, F. de Tomasi, L. Julien, and F. Biraben: *Phys. Rev. Lett.* **76**, (1996)384.
- [3] M. Weitz, A. Huber, F. Schmidt-Kaler, D. Leibfried, and T. W. Hänsch: *Phys. Rev. Lett.* **72**, (1994)328.
- [4] M. Weitz, A. Huber, F. Schmidt-Kaler, D. Leibfried, W. Vassen, C. Zimmermann, K. Pachucki, T. W. Hänsch, L. Julien, and F. Biraben: *Phys. Rev. A* **52**, (1995)2664.
- [5] T. Andreae, W. König, R. Wynands, D. Leibfried, F. Schmidt-Kaler, C. Zimmermann, D. Meschede, and T. W. Hänsch: *Phys. Rev. Lett.* **69**, (1992)1923.
- [6] F. Nez, M. D. Plimmer, S. Bourzeix, L. Julien, and F. Biraben: *Phys. Rev. Lett.* **69**, (1992)2326.

- [7] K. Pachucki, D. Leibfried, M. Weitz, A. Huber, W. König, and T. W. Hänsch: *J. Phys. B* **29** (1996)177.
- [8] M. Prevedelli, T. Freegarde, and T. W. Hänsch: *Appl. Phys. B* **60**, (1995)S241.
- [9] M. Kourogi, B. Widiyatomo, Y. Takeuchi, and M. Ohtsu: *IEEE J. QE*, **31** (1995)2120.
- [10] S. N. Bagayev, A. K. Dmitriev, A. E. Ohm, P. V. Pokasov, E. V. Shalnev, B. N. Skvortso, and V. A. Nikulin: to be published in *Laser Physics*
- [11] L. Ricci, M. Weidemüller, T. Esslinger, A. Hemmerich, C. Zimmermann, V. Vuletic, W. König, and T. W. Hänsch: *Opt. Comm.* **117**, (1995)541.
- [12] C. O. Weiss, G. Kramer, B. Lipphardt, E. Garcia: *IEEE J. QE* **24**, (1988)1970.
- [13] C. Zimmermann, V. Vuletic, A. Hemmerich, and T. W. Hänsch: *Appl. Phys. Lett.* **66**, (1995)2318.